

DESIGN FEATURES:

- Built-in ISO 5211 Direct Mounting Pad for Easy Automation
- **Fire Safe** Design
- Anti-static Devices for Ball-Stem-Body
- Blow-out Proof Stem
- Pressure Balance Hole in Ball Slot
- **TA-LUFT** Design Approved
- Casting Approved by TÜV AD 2000-Merkblatt W0
- Options: 1. Actuator 2. Limit Switch 3. Positioner

APPLICABLE STANDARDS:

- Design: DIN 3375 / 1, 2. EN12516-1
- Fire Safe: API 607 5th 2005, ISO 10497
- Wall Thickness: EN12516-1
- Flanged Ends : EN1092-1 PN10-PN40
- Inspection & Testing: DIN 3230/3, EN12266

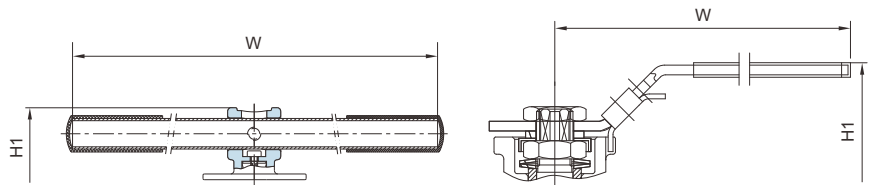
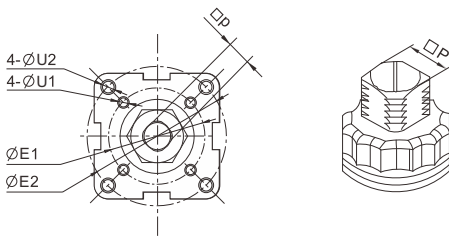

SIZE : DN 100 ~ DN 150

SIZE : DN 15 ~ DN 80

NO.	PART NAME	MATERIALS		
1	Body	1.4408	1.4308	1.0619
2	End Cap	1.4408	1.4308	1.0619
3	Ball	1.4408	1.4308	
4	Ball Seat	TFM1600 / PTFE / RTFE		
5	Stem	316	304	
6	Anti-Static Device	316	304	
7	Thrust Washer	PTFE		
8	O-Ring	FKM		
9	Stem Packing	PTFE / GRAFOIL*		
10	Bushing	50%SS + 50%PTFE / SUS 304*		
11	Gland	316		
12	Belleville Washer	301		
13	Stem Nut	A194-8		
14	Stop-lock-Cap	304		
15	Body Gasket	PTFE / 316 SPIRAL WOUND+GRAFOIL*		
16	Hex Bolting	A193-B8		
17	Actuator	Pneumatic KP / Electric KQ		

*Materials for KV-L7KF, KV-L7NF (Fire-Safe Models)

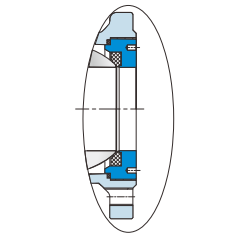
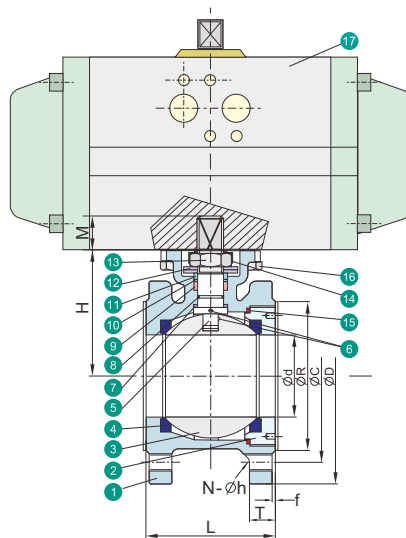

SIZE : DN 15 ~ DN 80

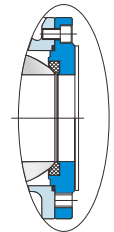

SIZE : DN 100 ~ DN 150

SIZE	PN	d	R	C	D	f	T	L	H1	W	H	M	P	N	h	U1	U2	E1	E2	ISO 5211	
DN15	1/2"	10~40	15.0	45	65	95	2	9	42	77	145	46.0	9	9	4	M12	6	6	36	42	F03-F04
DN20	3/4"	10~40	20.0	58	75	105	2	9	44	85	145	51.0	9	9	4	M12	6	7	36	50	F04-F05
DN25	1"	10~40	25.0	68	85	115	2	9	50	94	175	62.0	11	11	4	M12	6	7	42	50	F04-F05
DN32	1-1/4"	10~40	32.0	78	100	140	2	12	60	104	175	72.0	11	11	4	M16	6	9	42	70	F05-F07
DN40	1-1/2"	10~40	38.0	88	110	150	3	13	65	114	196	78.0	14	14	4	M16	7	9	50	70	F05-F07
DN50	2"	10~40	50.0	102	125	165	3	20	80	120	196	86.0	14	14	4	M16	7	9	50	70	F05-F07
DN65	2-1/2"	10/16	63.5	122	145	185	3	18	110	158	265	108.0	17	17	4	M16	9	11	70	102	F07-F10
		22						113													
DN80	3"	10/16	76.0	138	160	200	3	20	120	165	265	116.0	17	17	8	M16	9	11	70	102	F07-F10
		24						120													
DN100	4"	10/16	95.0	158	180	220	3	20	150	182	400	139.0	22	22	8	M16	N/A	11	N/A	102	F10
		162		190	235	24		154													
DN125	5"	10/16	118.0	188	210	250	3	22	180	224	800	176.0	27	27	8	M16	N/A	14	N/A	125	F12
		220			270	26															
DN150	6"	10/16	142.0	212	240	285	3	22	225	268	800	192.0	27	27	8	M20	N/A	14	N/A	125	F12
		218		250	300	28															

Unit: mm

KV-L7K, KV-L7KF— **PN16**

KV-L7N, KV-L7NF— **PN40**